

STANDARD SINGLE LANE TECHNICAL SPECIFICATIONS

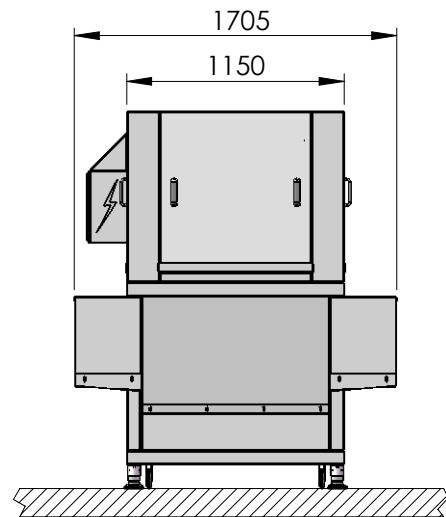

Technical Features

- Manufactured in 304 s/s with multiple easy access panels and hinged filter access door.
- Filtered air system to protect fan intake with easily removable filters for cleaning and replacement.
- High velocity fan blows air through air knife into passing baking pan, deflecting loose seeds and toppings into removable catchment trolley below.
- Trolley fitted with swivel castor wheels and magnetic catch.
- Stop/Start controls and isolator mounted within integrated 304 s/s panel c/w 45° sloping roof.
- Designed to fit over existing conveyors.
- Single and twin lane conveyor options available.
- Cantilever design and simple integration allows for quick install with minimum downtime.

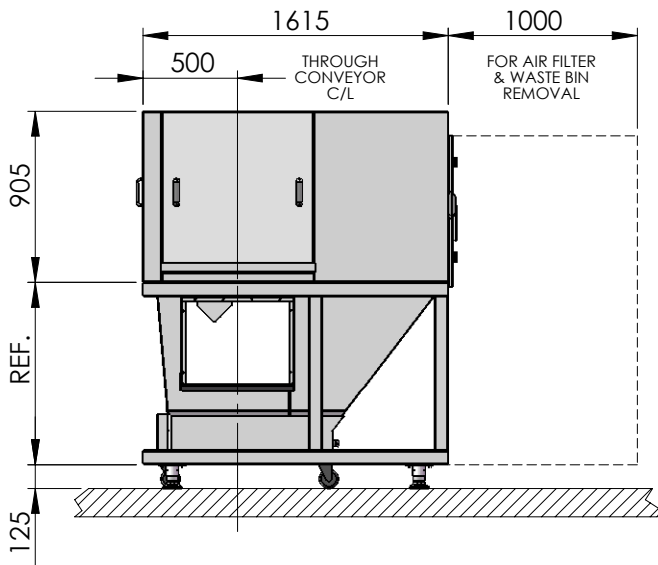
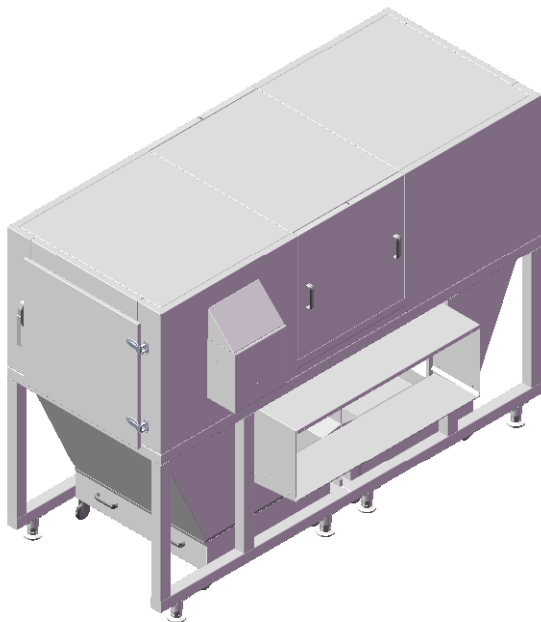

DOUBLE LANE - SHORT TUNNEL
VARIATION

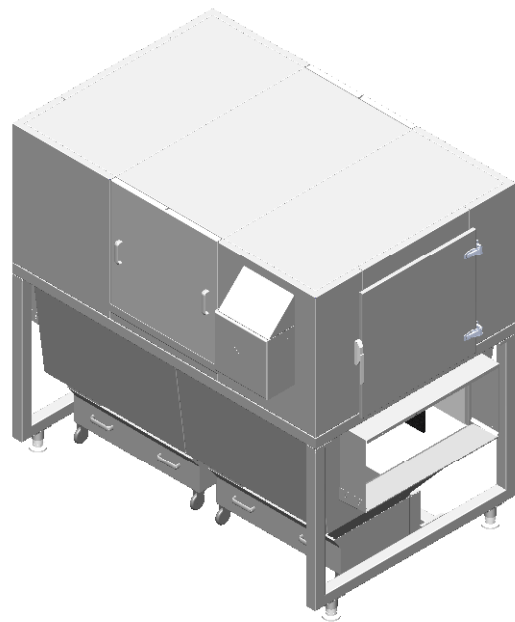

DOUBLE LANE - LONG TUNNEL
VARIATION

Due to continuous technical developments, specifications may be modified without notice



**Manufactures of Industrial Washing Machines
and Material Handling Equipment**

NEWSMITH PACIFIC SYSTEMS LIMITED
9 Desi Place, Woolston, Christchurch NZ.
P.O. Box 30060 St Martins, Christchurch NZ.

Tel: + 64 (0) 3 982 4244 Fax: + 64 (0) 3 982 4244
Email: sales@newsmith.co.nz